

FEINA, SF20 SOLAR TRACKER INSTALLATION MANUAL

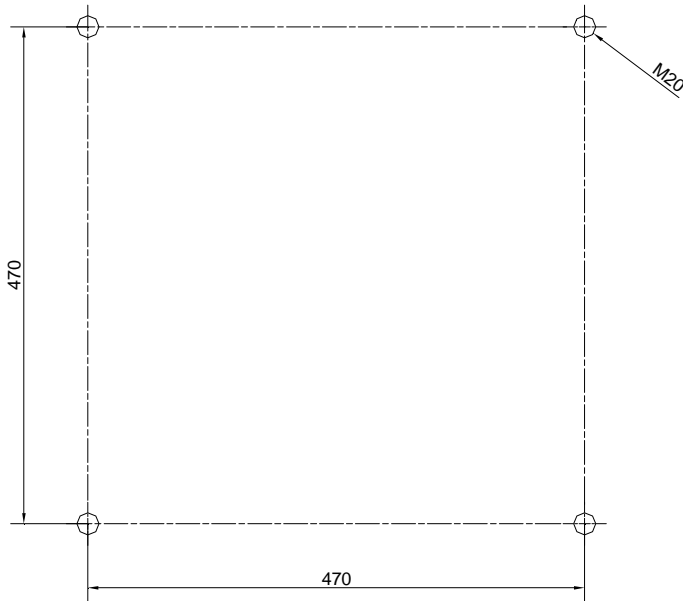

1- Make a concrete foundation , with four M20 threaded rods. They must extend 60 mm out of the concrete. The image shows the distance between the rods. We can provide a template to ensure these measurements.

The foundation, if it is for gravity, can be a 200 cm diameter by 70 cm high concrete block. If the ground is not very solid the foundation can be 200x200x65 cm. If it is solid, it can be smaller. We can advise you.

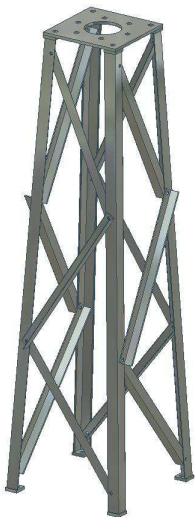

2- Place the iron column on the four M20 threaded rods.

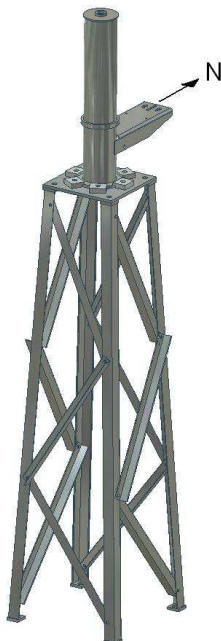

3- The set part must face north, as shown in the image (M20 nuts and bolts).

The 6 bolts have to be screwed with 590 Nm. Finding a distance reference with a topographical map or a satellite image makes determining north much more precise than with a compass.

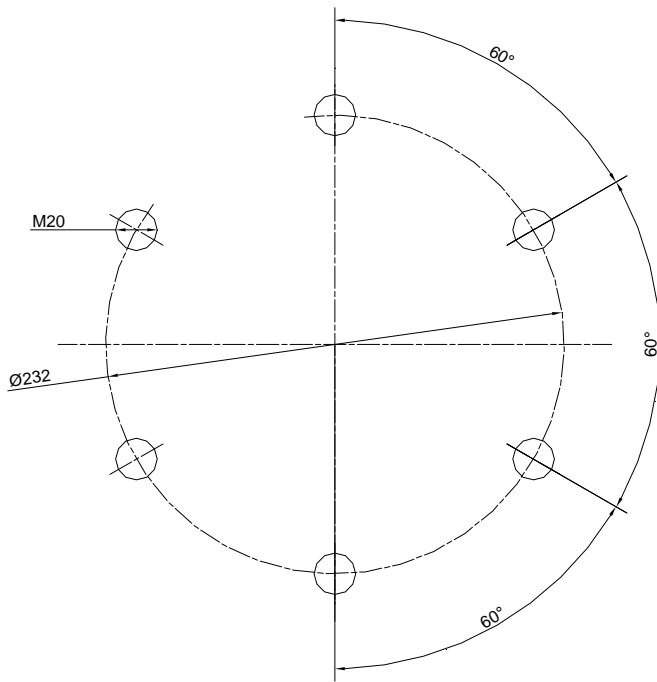

4- A concrete column can be used instead of an iron one. In this case, it should have M20 rods that come out some 60 mm. You can find the measurements in the attached drawing. We can supply a template.

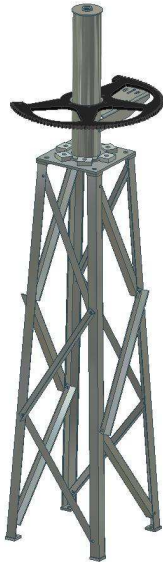

5- Install the time movement wheel.

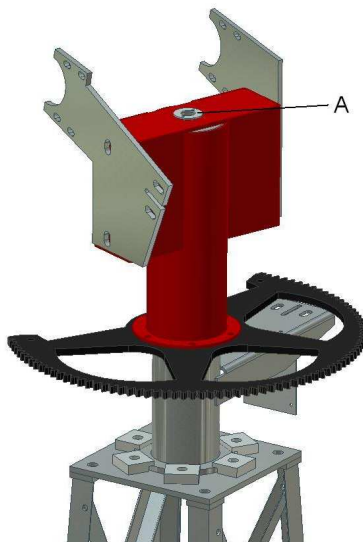

6- Attach the mobile part with 5 M14 bolts and nuts. It has a wheel (A) (M6 bolts) so the set will not come loose, and the two lateral pieces, with M20 nuts. The 5 M14 bolts have to be screwed with 200 Nm.

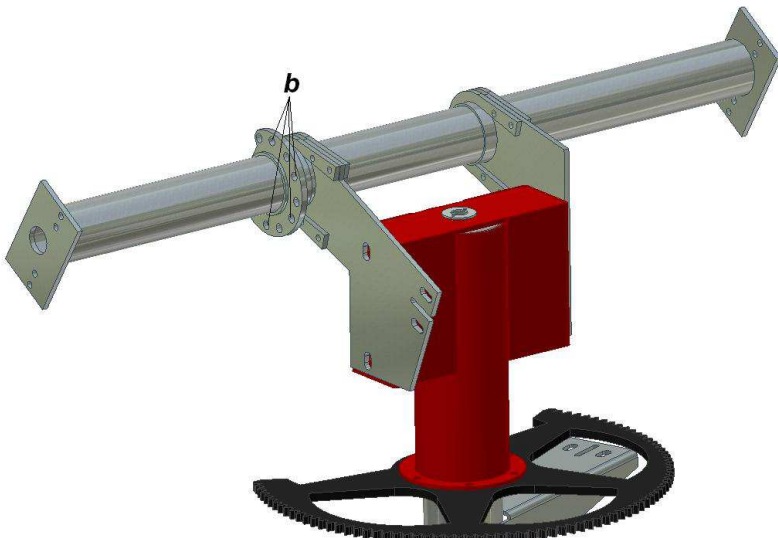

7- The main axle pipe must spin in the position shown in the image.



8- The cogged portion must be attached with the four M14 bolts and nuts. The 5 M14 bolts have to be screwed with 200 Nm. For flat panels and for the majority of concentration panels, the wheel has to be attached with the four holes as indicated by letter (b) in the previous image.



9- The motors must be placed as well as their protective boxes. The electrical panel should preferably be placed in the column and easy to see. Screw the M16 bolts with 300 Nm. Put grease in all gears and points of friction. This is repeated once or twice a year. Make sure the motor's power is at 12 volts and that it makes complete movements without getting jammed.

From that point, if concentration panels are installed, the mechanic structure may be different. If flat panels are installed, the structure must be built as shown below:



10-Screw on the two main bars.

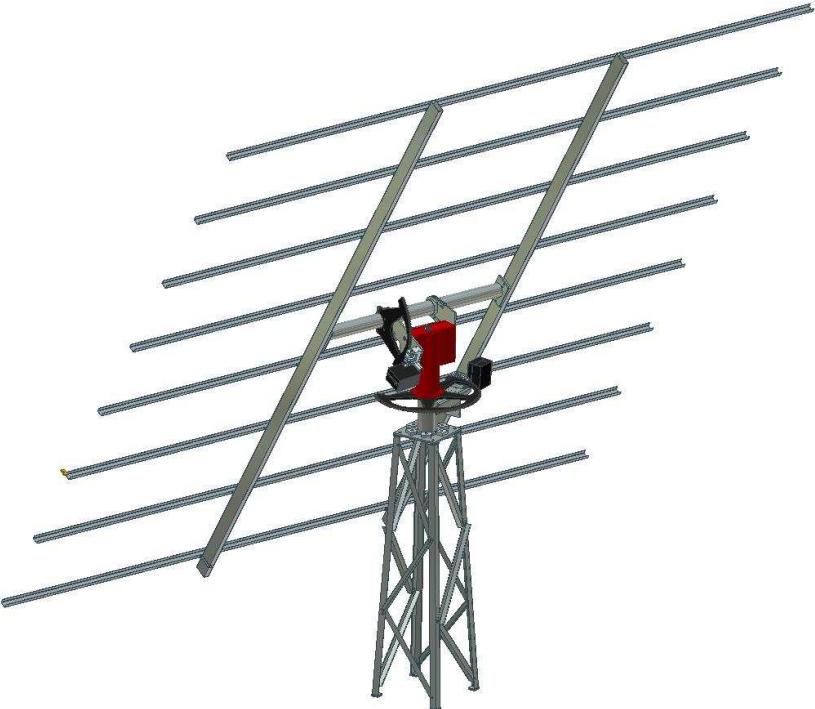

11- Place the bars in a “U” shape, as explained in detail further ahead. If the tracker is placed in a horizontal position feeding the motor with 12 V, can ease the task.

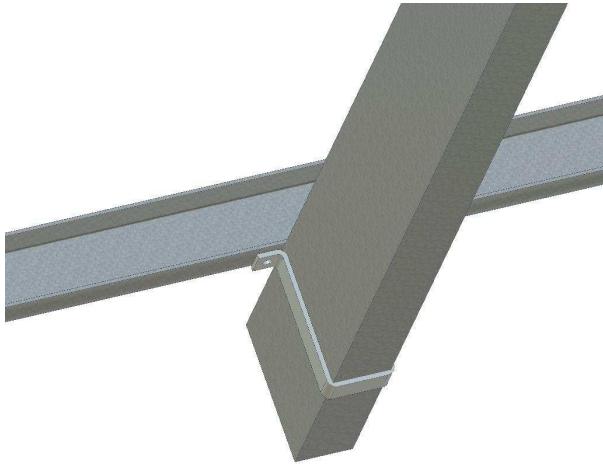

12- Next we'll fasten the bars at a distance that we consider to be the best for the panels that we want to mount.

13- Next plug in all the switches and connect the wires to the grid. (see details ahead). Turn on the device to test it.

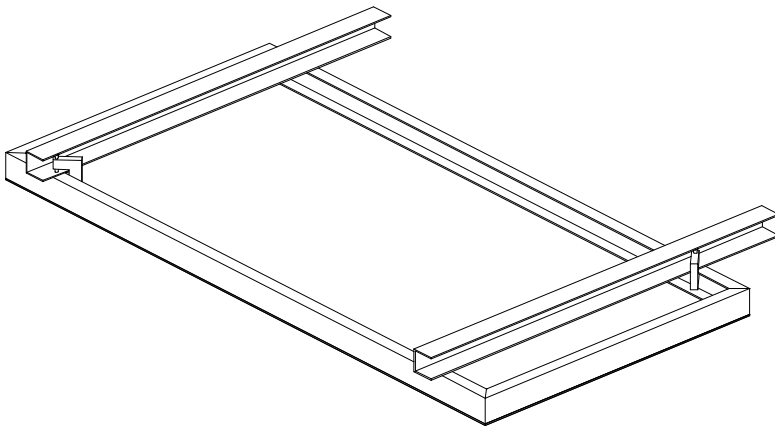

14- Set up the panels with the given bridles as it appears in the illustration.

ELECTRONICS AND PROGRAMMING

A wire from 1 to 4 mm² of section is connected (see further below), in the wire shaft found inside the hermetic box with the electrical system. It's marked with + and -, where the positive and negative are connected. Be careful not to invert the poles. Make the wire pass through the inner opening so that it remains quite hermetic.

From the box, the shortest cable goes to the hourly engine. The longest cable for the inclination engine.

Near the wire shaft is a switch. It turns on the electrical grid. After 2 seconds the following screen appears:

```
14/05/03  10:21
LON: E001°52`25` `
LAT:  N41°42`50` `
```

In other words, day, month, year, hour and minute.

The red button changes the day. Each time it's pressed the number increases one unit. When it reaches 31 it resets to 0. When the day is correct, continue to the black button for the next value to be changed, the month. Proceed as before. Just the same as with the year, hour and minute.

Be careful! You should set the universal time, not the official time. You can find with double click on the clock of your computer.

By the same procedure longitude and latitude must be set up. East (E) and west (W) for longitude and north (N) and south (S) for latitude.

At any moment, if the information were correct, you could move directly onto the following screen with the blue button.

Then appears the following:

```
1          01
Incline axis
Black: vertical
Red: horizon.
```

The two ones or zeros that appear in the top right extreme of the screen informs us about the state of the two counter switches. The first number indicates if the counter switch of the axis of inclination is activated. (1: connected, 0: disconnected). The second number indicates the state of the hourly counter.

These two numbers can be very useful to know if any switch doesn't work.

With the two buttons we'll position the axis of inclination until achieving the correct inclination with regard to the inclination of the Sun in this moment (If it's evening or cloudy it will be best to wait for the Sun to come out).

Press the blue button again and then appears:

```
2          01
6
```

Hourly axis
Black: east
Red: west

With the two buttons we'll position the hourly axis until the base faces the Sun.

Then, only for solar sensor systems, we will have on the screen:

HOR:129
VER:123
LLU:085

When the sun is well pointed, value hor and ver it must be near 128. Value LLU means the light. If it is bellow to some determinate value, the solar sensor do not work and tracker works by astronomical program.

Even if is for concentration or not, by pressing the blue button we will go to the normal function screen:

14/05/03 16:21
HOR: +270° 0120
VER: +022° 0001
00 00 120 243 01

On this screen the date, hour and minutes are displayed. By pressing the black button we'll increment the minutes and the red button will decrease them.

The following line is the hourly position. 90° is when the tracker faces east, 180° is when it faces south and 270° when it faces west.

Next, on the same line is the number of impulses given by this axis from the start of the day.

The third line, is the same but with the axis in vertical movement. It would be 0° if the tracker were completely vertical and 90° completely horizontal.

The numbers on the forth line are control numbers. At any rate, the last number indicates the minutes left to calculate the position of the tracker and begin to function, if this were the case, the motors.

By pressing the blue button we'll return to the two previous screens in order to adjust the tracker to face the Sun.

MALFUNCTION WARNINGS

When an motor doesn't work, or the tracker gets stuck or the switches fail, etc. the electronics detects it and an error message appears on the screen while the motors disconnects. There are two possible errors:

ERROR 26: The axis of inclination. This error appears on the screen when the electronics has ordered the inclination motor to start and during several seconds it has not detected any

change of state in the counter switch of the engine. It's always opened or closed. From which it is deduced that one of the following things could occur:

- A) The inclination motor doesn't function
- B) The connections to the inclination motor fail
- C) The switch doesn't work or doesn't get activated
- D) The switch connections fail.
- E) The tracker is obstructed and therefore cannot move

ERROR 27: The same as in the previous error but with the hourly axis.

In two errors, the number of seconds that remains without receiving a signal change before disconnecting motors and going out, the error notice comes with a 6 second delay. In any event it's possible to change between 1 and 25 seconds. (See ahead, the V variable).

CONFIGURATION OF SOME PARAMETERS

By default this tracker already comes programmed so that it works perfectly, but it has a great flexibility to adapt itself to an infinite number of circumstances.

By changing the value of some variables we'll be able to extend or to correct functions.

If we want to change variables we'll have to do the following:

Press the connection switch and before 2 seconds of connection goes by, press the red button.

A screen will appear before us where there are 8 values, from A to H. With the red button we can change every value and with the black button we can proceed to the following value. When we come to the value H, by pressing the black button we'll continue to the following screen where the values from I to P will appear, and by the same method a third screen with values from Q to X.

Some variables are not applicable, other are. Here is an enumerated list of the different variables and their uses:

A: Clock velocity: By default it is 128, values are from 0 to 256. If the clock tend to move forward, to drop the value (127, 126, 125). For each unit we drop, clock will move backward 1.38 seconds daily. And will the other way around if we move forward the value.

B: (only for concentration) Value of the light of the sun. By default 76, usually a powerful sun it is 95. To adjust this value (that it may vary with the sensor), point the tracker to the sun (with clear sky) and sun above 30°. Write down the value "LLU" on the 3rd screen. Of than number take out 20. An this is the value that must be in parameter B. For example is "LLU" is 94, parameter B must be 74

C: Minimal inclination of the tracker with regard to the vertical one. By default it's at 22°. The status goes from 0 to 85°. The tracker allows itself to set at almost 0° but it's not advisable because depending on the position with the axis of inclination it might run into any obstacle.

Modifying this variable can serve us for several things. For example, if we have an obstacle that makes interference when the device is very vertical. If for whatever reasons that maybe, we only want the hourly axis to move, we can put this variable to 85°. Such as in European latitudes the Sun never reaches this inclination, the axis of inclination will never move.

D: (only for concentration) hipster. It can be 3 if a really high accuracy is needed or 25 if is not needed. Below 3 tracker would have not enough stability. In the screen with parameters "HOR, VER LLU", the first two numbers are the vertical and horizontal axis. The ideal value is 128, if the hipsters value is 10, it will always be between 118 and 138

E: Range of movement from east to west. By default, 180°. Otherwise, from the midday position, (south), the range of movement will be +/- 90°. It can be programmed from 0 to 255°.

In the case of 255° it would mean that it would go from -127,5° (Northeast) to +127,5° (Northwest) in reference to the south. Anyhow, the tracker doesn't permit such a wide range of movement.

F: Number of impulses from the switch of the hourly motor to complete its hourly course. By default 267. The number of impulses that the tracker generates to complete 180° that exists for default, is 267 in SF9, 0400 in SF20, 560 in SF28 and 0641 in SF45

If, in an SF20, we only want it to do 150°, besides modifying the variable I, we'll have to modify F, since doing 150° will only create 333 impulses.

G: Time, in minutes, between movements of the tracker. It can be programmed between 1 and 98 minutes. If it's 30 minutes, it means that every 30 minutes it will calculate the position of the Sun and if they correspond, the tracker will move. On the normal functioning screen the number that on the fourth line to the right indicates the number of minutes remaining until the next calculation.

H: Language. From 1 to 4. Number 4 is English

I: Night position activation. If it's at 0 the tracker will do its normal day movement and in the evening, when the Sun set, it will turn to the back towards the East, keeping the tracker in next closest vertical position (by default 22°). If it's at 1, in the evening the tracker shifts to horizontal. This can be useful to make the access to the panels difficult avoiding robbery. It can also be useful to minimise the time of vertical position in which it's in when the wind is the strongest. Although normally the maximum winds aren't at night but during the afternoon.

J: (only for concentration) Period of measuring of the solar sensor, in minutes. The default value is 82, and it measures the value every 10 seconds.

K: Not applicable

L: A useful parameter that helps the tracker to "count" properly on the inclination axis when the tracker is not equilibrated. If the tracker, due to its weigh, it would reach a too vertical position it could loose some impulse. This parameter can be set up to 2 or 3 (instead of 0 by default).

M: Not applicable

N: This is the way that the tracker can run from the south till it finish the East gear. By default 106°. This is very useful when there is an automatic restart. If the foundation of the tracker is not pointing perfectly to the north, the value can be changed and get a more precise tracking system.

O: Maximum verticality of the tracker before it shocks with the inclination gear stopper. By default 4°

P: Only applicable for tracker connected on net. The identification number of the tracker.

Q: Angle, from vertical, when the wind safe position is set.

R: Not applicable

S: Not applicable

T: Not applicable

U: Not applicable

V: Time, in seconds, in which the electronics should be without receiving a signal to show the error. By default 6 seconds. It can be adjusted between 1 and 25 seconds.

X: Time, in minutes, by which the tracker will set itself horizontally if given the order because of the wind. By default 60 minutes. Values adjust from 10 to 190 minutes.

In the electrical grid there is a wire shaft of two contacts, one indicated with "V", that if the circuit closes between these two contacts, the tracker will set itself for us horizontally during the programmed time. If we have an anemometer that at a certain wind speed closes a circuit, it will allow us to use this system for major protection from winds.

SEMI AUTOMATIC INITIALIZATION :

Once position, date and hour are correctly set up:

- 1- Switch on the electronic controller
- 2- Press the blue button before 2 seconds have passed by.

The tracker will start moving to the east till the stopper of the gear stops it. Once it stops it will take that point as a reference. After this it will go to the west till the point it should be according the time. The same procedure must be done with inclination axis.

AUTOMATIC INITIALIZATION:

A GPS system can be provide. It allows to, automatically, set the exact time, date and position, and tracker will start working automatically.

All functions (also the GPS initialization) can be done from a central unit of control that connects all the trackers

(A13 version).

Trackers Feina SL,
Fàbrica el Molinet s/n
08250 Sant Martí de Torruella(Barcelona)
Tel:93 875 1001
feina@tracker.cat
<http://www.tracker.cat>

